

Hydraulic Dampers

Multi-talent in speed control

The ACE hydraulic dampers are similar in appearance to our industrial gas springs but are adjusted in the end position and work differently to the DVC family with individual speed adjusters for the push and pull direction. This provides users with the maximum flexibility.

Whether used as drive compensation or safety element, the retraction and extension speed of these ACE solutions can always be precisely set. This means that the speed of movement can be controlled, synchronization regulated in both directions and pivoting loads can be compensated. Depending on the model, the push and pull forces are between 6.75 lb to 2,023 lb (30 N and 40,000 N). These maintenance-free, ready-to-install products are available in body diameters of 0.47 in to 2.75 in (12 mm to 70 mm) and in stroke lengths up to 31.50 in (800 mm).



Hydraulic Dampers



DVC-32 and DVC-2 to DVC-6

Page 194

Adjustable, Without Free Travel

Multi-directional speed adjustment

Cylinder speed controls, Absorption control, Finishing and processing centers



HBD-15 to HBD-40

Page 196

Adjustable

Regulation at the highest level

Finishing and processing centers, Machine housing, Hoods, Shutters



HB-12 to HB-70

Page 202

Adjustable

Linear motion control

Conveyor systems, Transport systems, Furniture industry, Locking systems

Constant speed rates

Sensitive adjustment

High quality and long lifetime

Easy to mount



DVC-32 and DVC-2 to DVC-6

Multi-directional speed adjustment

Adjustable, Without Free Travel

Compression and extension force 9.44 lbs to 450 lbs

Stroke 2.00 in to 6.00 in

Separately regulated in any stroke position: The hydraulic dampers of the product family DVC-32 and DVC-2 to DVC-6 are the first dampers to provide precise, independent, external adjustment of in-and-out speeds. With their individual adjustments for the push and pull direction as well as the bi-directional action, these are suitable as safety or control elements.

The great number of mounting accessories makes assembly of these ACE hydraulic dampers easier and allows these maintenance-free, ready-to-install and self-contained systems universally applicable. Qualitatively high grade, and at the same time simple to use; one of their uses is to absorb swinging loads.

These velocity controllers are used in the automotive sector, automation and machine building as well as in the electronics industry.

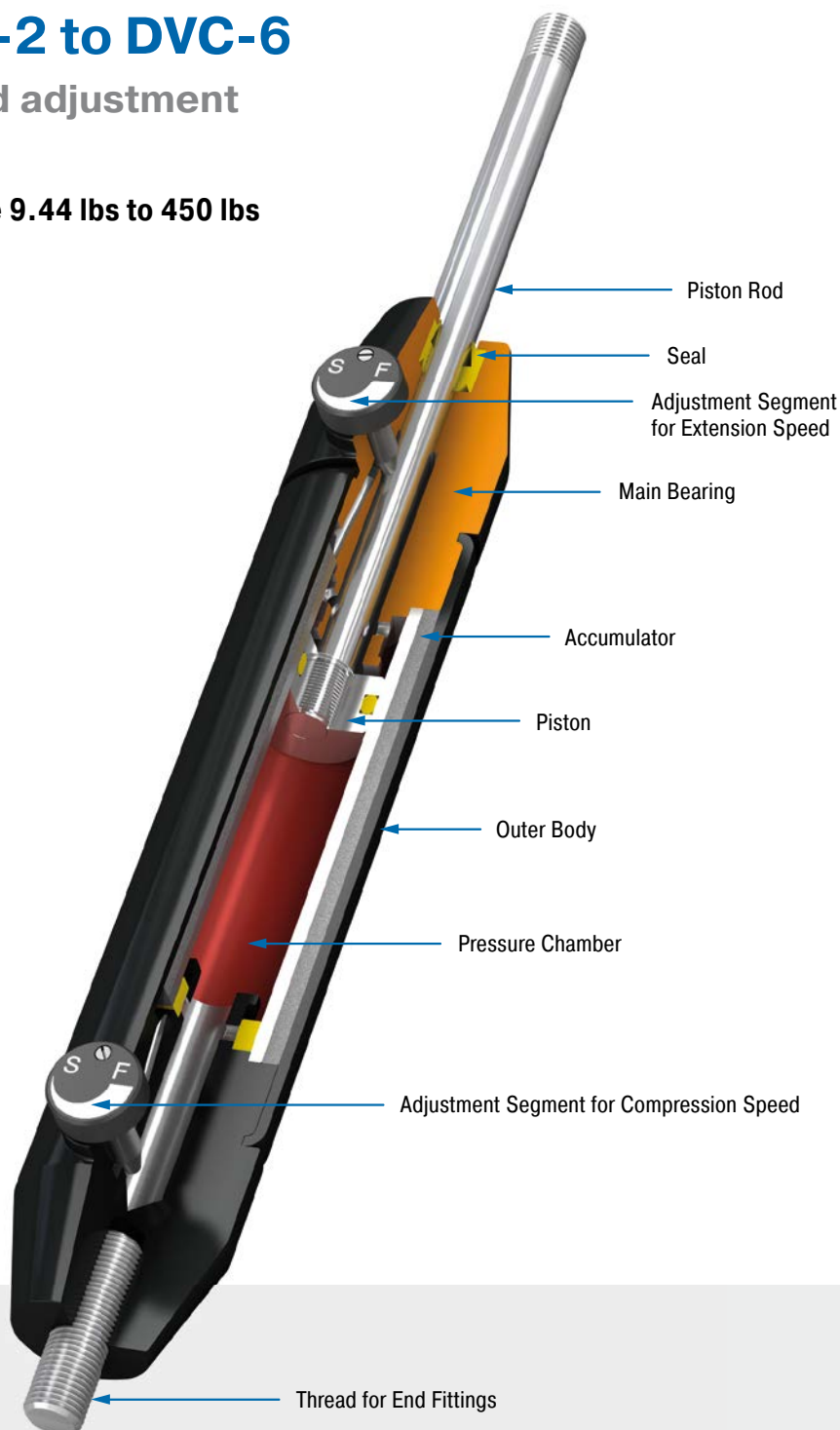

Technical Data

Compression and extension force:
9.44 lbs to 450 lbs

Outer body diameter: Ø 1.26 in

Piston rod diameter: Ø 0.31 in

Lifetime: Approx. 250,000 cycles

Operating temperature range: 32 °F to 149 °F

Adjustment: Steplessly adjustable

Positive stop: External positive stops 0.04 in to 0.06 in before the end of stroke provided by the customer.

Damping medium: Automatic Transmission Fluid (ATF)

Material: Outer body: Coated aluminium; Piston rod: Hard chrome plated steel; End fittings: Zinc plated steel

Mounting: In any position

Application field: Cylinder speed controls, Absorption control, Finishing and processing centers

Note: Increased break-away force if unit has not moved for some time. Damping force can be adjusted after installation.

End fittings: They are interchangeable and if necessary must be positively secured by the customer to prevent unscrewing.

On request: Special oils and other special options. Alternative accessories available on request.

Adjustable, Without Free Travel, Compression and extension force 9.44 lbs to 450 lbs

End Fitting

Standard Dimensions

End Fitting

A8

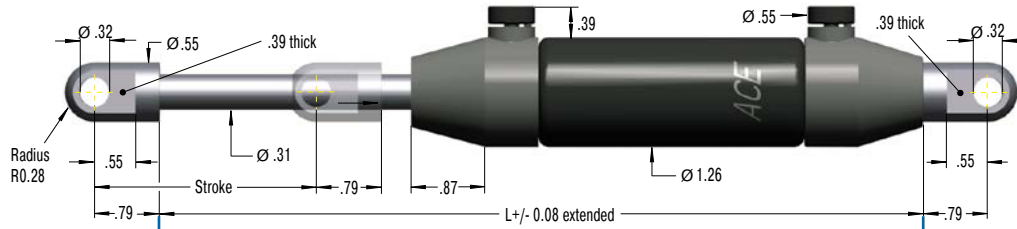

Eye A8
max. force 674 lbs

B8



Performance and Dimensions

TYPES	Stroke inch	L extended inch	¹ Compression force max. lbs
DVC-32-50	2.00	9.45	300
DVC-32-100	4.00	13.39	350
DVC-32-150	6.00	17.32	450

¹ Max. extension force for all stroke lengths 449.62 lbs.

Stud Thread B8

C8

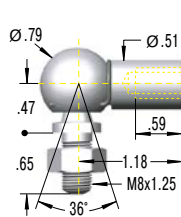

Angle Ball Joint C8
max. force 270 lbs
Also available with
UNF thread 5/16-18.
Order G5/16.

D8

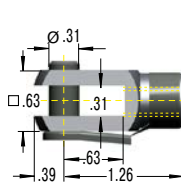

Clevis Fork D8
max. force 674 lbs

E8

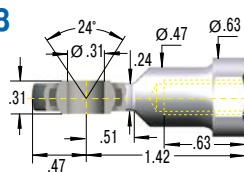

Swivel Eye E8
max. force 674 lbs

Ordering Example

DVC-32-50-DD-CCO

- Type (Hydraulic Damper) _____
- Body Ø 1.26" (32 mm) omitted at DVC-2 to DVC-6 _____
- Stroke 2" (50 mm) _____
- Piston Rod End Fitting D8 _____
- Body End Fitting D8 _____
- Velocity Controls (Omit prefix for controlled, both directions) _____

Model Type Prefix

- : Controlled, both directions
- CCO: Controlled, compression only
- CTO: Controlled, tension only

End fittings: They are interchangeable and if necessary must be positively secured by the customer to prevent unscrewing.

Mounting accessories see from page 212.

DVC-2 to DVC-6

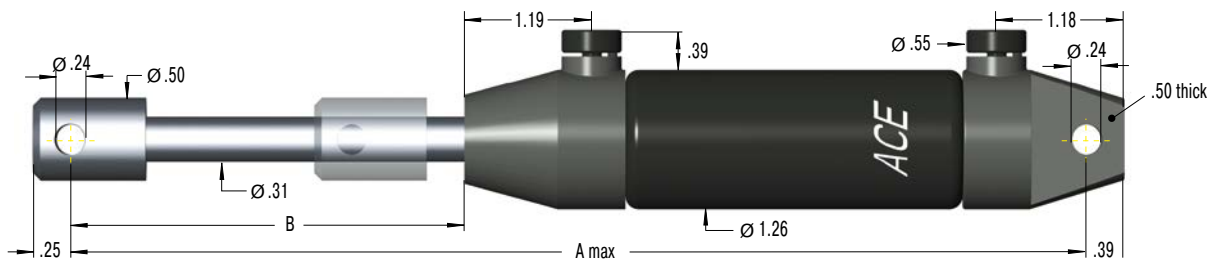

Performance and Dimensions

TYPES	Stroke inch	A max. inch	B inch	Compression force max. lbs	Traction force max. lbs
DVC-2	2.00	9.81	2.96	450	450
DVC-4	4.00	13.81	4.94	450	450
DVC-6	6.00	17.81	6.94	450	450

HBD-15 to HBD-40

Regulation at the highest level

Adjustable

Compression and extension force 8 lbs to 2,248 lbs

Stroke 0.98 in to 31.5 in

ACE Controls HBD Hydraulic Dampers are maintenance-free, self-contained and sealed units. They are available with body diameters from 0.59" (15 mm) to 1.57" (40 mm) and with stroke lengths of up to 31.5" (800 mm). Unlike standard Hydraulic Dampers that include free travel up to 20 % of stroke, these dependable units have no free travel and are ideal for applications that require this level of performance. Double-acting Hydraulic Dampers are standard. However, a single acting design is available. Adjustment is easily achieved by pulling and turning the rod until the desired damping speed is achieved. The travel speed is adjustable and remains constant throughout the stroke.

The single acting version is controllable in one direction only, with free-flow in the opposite direction. A built-in antilock guard allows adjustment to be made at any damping rate without unit lock up. These reliable units offer long life-cycle performance. A variety of end fittings are available for ease of operation and installation, and are included.

HBD hydraulic dampers are used for process control, machine guards, lids, hatches, fire safety doors, arms for medical equipment, conveyors, swinging loads, machine tools, lift gates, drill feed control, amusement park rides, and more.

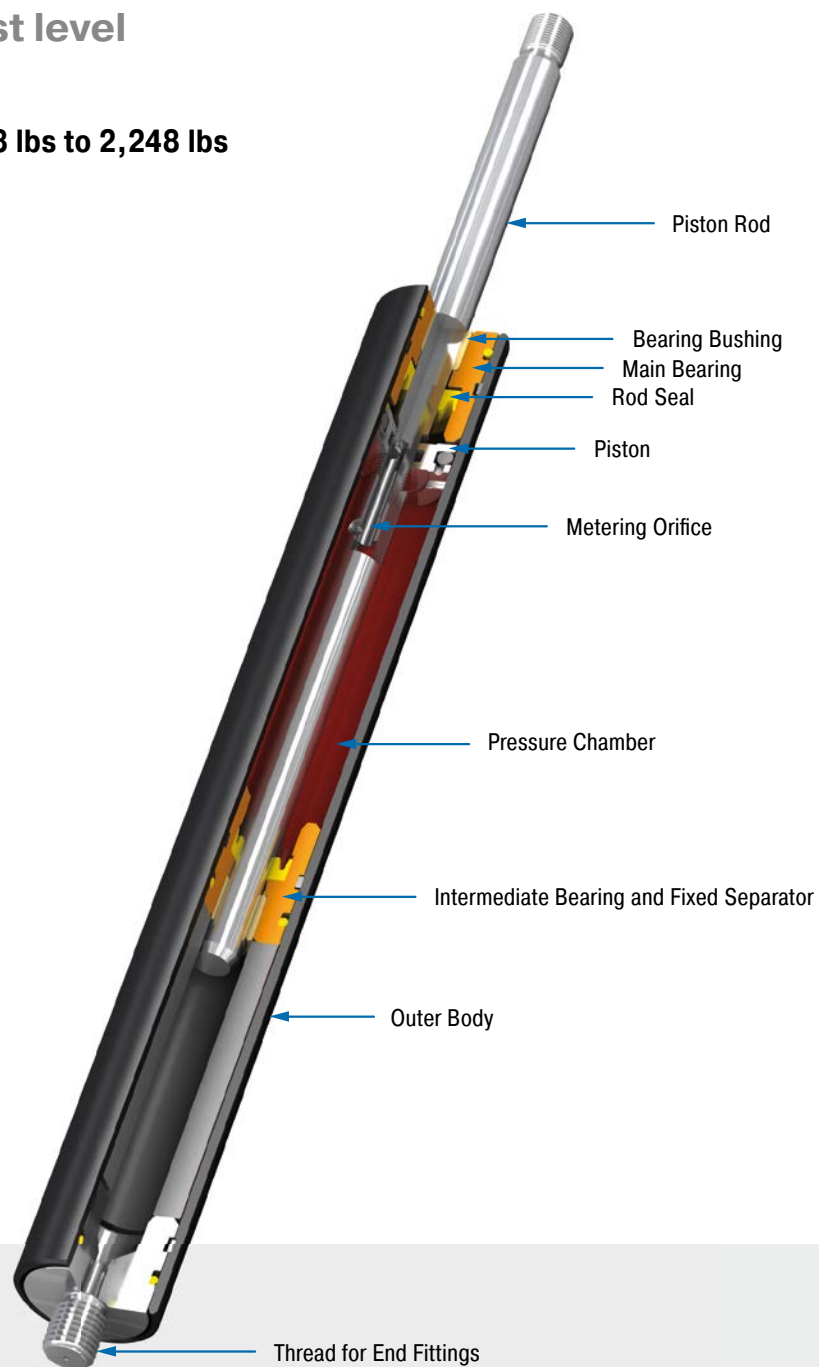

Technical Data

Compression and extension force: 8 lbs to 2,248 lbs

Outer body diameter: Ø 0.59 in to Ø 1.57 in

Piston rod diameter: Ø 0.24 in to Ø 0.55 in

Lifetime: Approx. 250,000 cycles

Free travel: These units have no free travel and are ideal for applications that require this level of performance.

Operating temperature range: -4 °F to 176 °F

Adjustment: Pull the piston rod out to its fully extended position. While pulling on the rod, turn it clockwise or counter-clockwise until the desired damping is achieved. The adjustment

is multi-turn and correct damping may require several trial and error adjustments. A built-in antilock guard allows adjustments to be made at any damping rate without unit lock up.

Positive stop: External positive stops 0.04 in to 0.06 in before the end of stroke provided by the customer.

Damping medium: Petroleum oil

Material: Outer body: Black anodized aluminium; Piston rod: Hard chrome plated steel; End fittings: Zinc plated steel

Mounting: In any position

Application field: Finishing and processing centers, Machine housing, Hoods, Shutters,

Fire safety doors, Medical technology, Conveyor systems, Swivel units, Tool machines, Lift doors

Note: Increased break-away force if unit has not moved for some time.

End fittings: They are interchangeable and if necessary must be positively secured by the customer to prevent unscrewing.

Safety information: Mechanical Stop required 0.04 in to 0.06 in before end of stroke.

On request: Special oils, damping characteristics, and stroke lengths. Alternative accessories available on request.

Adjustable, Compression and extension force 8 lbs to 180 lbs

End Fitting

Standard Dimensions

End Fitting

Performance and Dimensions

TYPES	Stroke inch	L extended inch	¹ Compression force max. lbs
HBD-15-25	0.98	5.71	179.85
HBD-15-50	1.97	8.66	179.85
HBD-15-75	2.95	11.61	179.85
HBD-15-100	3.94	14.57	78.68
HBD-15-150	5.91	20.47	67.44

¹ Max. extension force for all stroke lengths 180 lbs.

Ordering Example

HBD-15-150-AA-P

- Type (Hydraulic Damper)
- Body 0.59" (15 mm)
- Stroke 5.91" (150 mm)
- Piston Rod End Fitting A5
- Body End Fitting A5
- Damping Direction (P = in both directions)

Model Type Prefix

- P = Damping in both directions
- N = Damping on in stroke only
- M = Damping on out stroke only
- X = Special model suffix

Mounting accessories see from page 212.

Technical Data

Compression and extension force: 8 lbs to 180 lbs

Free travel: These units have no free travel and are ideal for applications that require this level of performance.

Operating temperature range: -4 °F to 176 °F

Adjustment: Pull the piston rod out to its fully extended position. While pulling on the rod, turn it clockwise or counter-clockwise until the desired damping is achieved. The adjustment is multi-turn and correct damping may require several trial and error adjustments. A built-in antilock guard allows adjustments to be made at any damping rate without unit lock up.

Positive stop: External positive stops 0.04 in to 0.06 in before the end of stroke provided by the customer.

Material: Outer body: Black anodized aluminium; Piston rod: Hard chrome plated steel; End fittings: Zinc plated steel

Mounting: In any position

Note: Increased break-away force if unit has not moved for some time.

End fittings: They are interchangeable and if necessary must be positively secured by the customer to prevent unscrewing.

Safety information: Mechanical Stop required 0.04 in to 0.06 in before end of stroke.

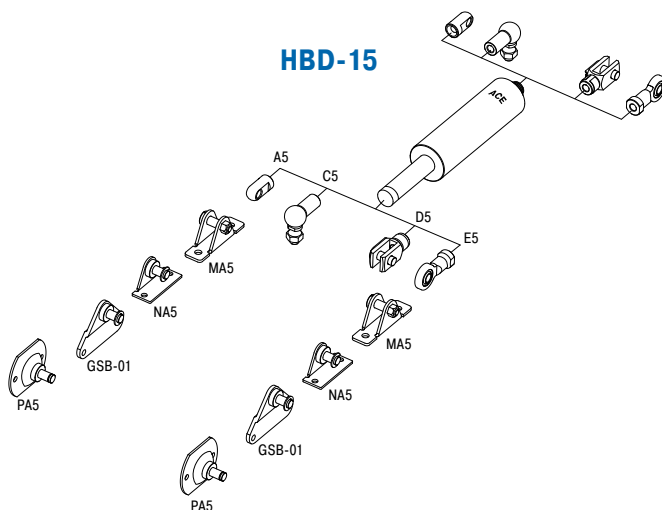

Adjustable, Compression and extension force 12 lbs to 405 lbs

End Fitting

Standard Dimensions

End Fitting

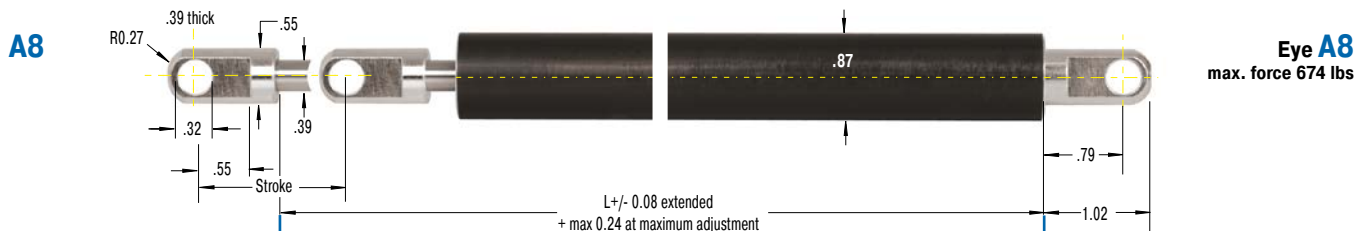

B8

C8

D8

E8

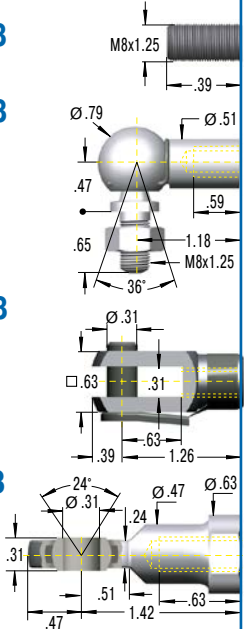

Performance and Dimensions

TYPES	Stroke inch	L extended inch	¹ Compression force max. lbs
HBD-22-50	1.97	9.25	404.66
HBD-22-100	3.94	15.16	404.66
HBD-22-150	5.91	21.06	404.66
HBD-22-200	7.87	26.97	224.81
HBD-22-250	9.84	32.87	224.81
HBD-22-300	11.81	38.78	179.85
HBD-22-350	13.78	44.69	134.89
HBD-22-400	15.75	50.59	89.92

¹ Max. extension force for all stroke lengths 405 lbs.

Ordering Example

HBD-22-150-AA-P

Type (Hydraulic Damper) _____
 Body 0.87" (22 mm) _____
 Stroke 5.90" (150 mm) _____
 Piston Rod End Fitting A8 _____
 Body End Fitting A8 _____
 Damping Direction (P = in both directions) _____

Model Type Prefix

- P = Damping in both directions
- N = Damping on in stroke only
- M = Damping on out stroke only
- X = Special model suffix

Mounting accessories see from page 212.

Eye **A8**
max. force 674 lbs

Stud Thread **B8**

Angle Ball Joint **C8**
max. force 270 lbs
Also available with
UNF thread 5/16-18.
Order G5/16.

Clevis Fork **D8**
max. force 674 lbs

Swivel Eye **E8**
max. force 674 lbs

Technical Data

Compression and extension force: 12 lbs to 405 lbs

Free travel: These units have no free travel and are ideal for applications that require this level of performance.

Operating temperature range: -4 °F to 176 °F

Adjustment: Pull the piston rod out to its fully extended position. While pulling on the rod, turn it clockwise or counter-clockwise until the desired damping is achieved. The adjustment is multi-turn and correct damping may require several trial and error adjustments. A built-in antilock guard allows adjustments to be made at any damping rate without unit lock up.

Positive stop: External positive stops 0.04 in to 0.06 in before the end of stroke provided by the customer.

Material: Outer body: Black anodized aluminium; Piston rod: Hard chrome plated steel; End fittings: Zinc plated steel

Mounting: In any position

Note: Increased break-away force if unit has not moved for some time.

End fittings: They are interchangeable and if necessary must be positively secured by the customer to prevent unscrewing.

Safety information: Mechanical Stop required 0.04 in to 0.06 in before end of stroke.

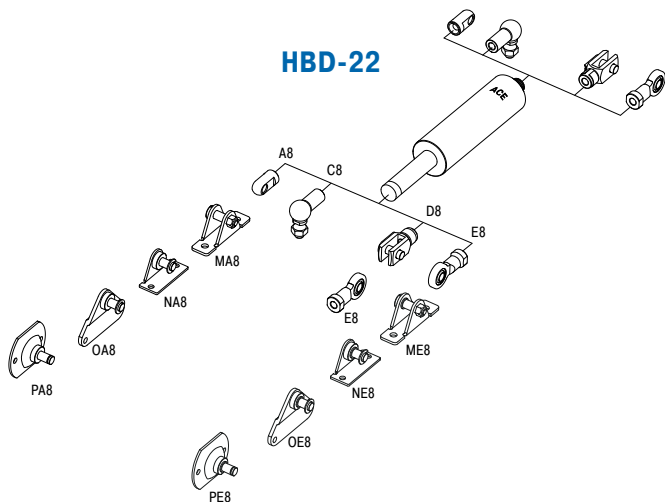

Adjustable, Compression and extension force 16 lbs to 674 lbs

End Fitting
Standard Dimensions
End Fitting

Performance and Dimensions

TYPES	Stroke inch	L extended inch	¹ Compression force max. lbs
HBD-28-50	1.97	9.85	674.43
HBD-28-100	3.94	15.75	674.43
HBD-28-150	5.91	21.66	674.43
HBD-28-200	7.87	27.56	674.43
HBD-28-250	9.84	33.47	674.43
HBD-28-300	11.81	39.37	562.03
HBD-28-350	13.78	45.28	449.62
HBD-28-400	15.75	51.19	337.22
HBD-28-500	19.69	63.00	224.81

¹ Max. extension force for all stroke lengths 674 lbs.

Ordering Example

HBD-28-150-AA-P

Type (Hydraulic Damper) _____
 Body 1.10" (28 mm) _____
 Stroke 5.91" (150 mm) _____
 Piston Rod End Fitting A8 _____
 Body End Fitting A8 _____
 Damping Direction (P = in both directions) _____

Model Type Prefix

P = Damping in both directions
 N = Damping on in stroke only
 M = Damping on out stroke only
 X = Special model suffix

Mounting accessories see from page 212.

Technical Data
Compression and extension force: 16 lbs to 674 lbs

Free travel: These units have no free travel and are ideal for applications that require this level of performance.

Operating temperature range: -4 °F to 176 °F

Adjustment: Pull the piston rod out to its fully extended position. While pulling on the rod, turn it clockwise or counter-clockwise until the desired damping is achieved. The adjustment is multi-turn and correct damping may require several trial and error adjustments. A built-in antilock guard allows adjustments to be made at any damping rate without unit lock up.

Positive stop: External positive stops 0.04 in to 0.06 in before the end of stroke provided by the customer.

Material: Outer body: Black anodized aluminium; Piston rod: Hard chrome plated steel; End fittings: Zinc plated steel

Mounting: In any position

Note: Increased break-away force if unit has not moved for some time.

End fittings: They are interchangeable and if necessary must be positively secured by the customer to prevent unscrewing.

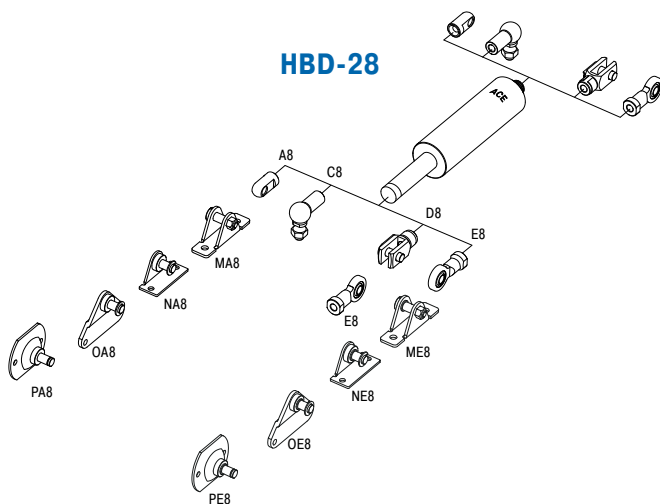
Safety information: Mechanical Stop required 0.04 in to 0.06 in before end of stroke.

Adjustable, Compression and extension force 18 lbs to 2,248 lbs

End Fitting

Standard Dimensions

End Fitting

Performance and Dimensions

TYPES	Stroke inch	L extended inch	¹ Compression force max. lbs
HBD-40-100	3.94	16.93	2,248.10
HBD-40-150	5.91	22.83	2,248.10
HBD-40-200	7.87	28.74	2,248.10
HBD-40-300	11.81	40.55	2,248.10
HBD-40-400	15.75	52.36	1,798.48
HBD-40-500	19.69	64.17	1,348.86
HBD-40-600	23.62	75.98	899.24
HBD-40-700	27.56	87.80	674.43
HBD-40-800	31.50	99.61	449.62

¹ Max. extension force for all stroke lengths 2,248 lbs.

Ordering Example

HBD-40-300-AA-P

Type (Hydraulic Damper) _____
 Body 1.57" (40 mm) _____
 Stroke 11.81" (300 mm) _____
 Piston Rod End Fitting A14 _____
 Body End Fitting A14 _____
 Damping Direction (P = in both directions) _____

Model Type Prefix

P = Damping in both directions
 N = Damping on in stroke only
 M = Damping on out stroke only
 X = Special model suffix

Mounting accessories see from page 212.

Technical Data

Compression and extension force: 18 lbs to 2,248 lbs

Free travel: These units have no free travel and are ideal for applications that require this level of performance.

Operating temperature range: -4 °F to 176 °F

Adjustment: Pull the piston rod out to its fully extended position. While pulling on the rod, turn it clockwise or counter-clockwise until the desired damping is achieved. The adjustment is multi-turn and correct damping may require several trial and error adjustments. A built-in antilock guard allows adjustments to be made at any damping rate without unit lock up.

Positive stop: External positive stops 0.04 in to 0.06 in before the end of stroke provided by the customer.

Material: Outer body: Black anodized aluminium; Piston rod: Hard chrome plated steel; End fittings: Zinc plated steel

Mounting: In any position

Note: Increased break-away force if unit has not moved for some time.

End fittings: They are interchangeable and if necessary must be positively secured by the customer to prevent unscrewing.

Safety information: Mechanical Stop required 0.04 in to 0.06 in before end of stroke.

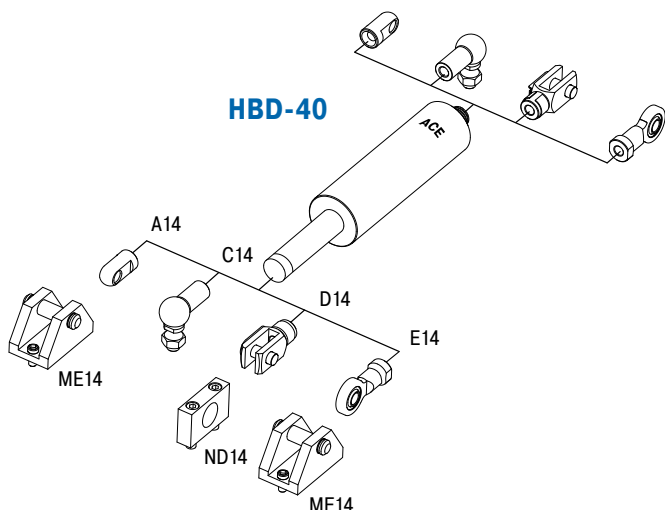

Dream it

We. Love. Challenges.



Ok, pure gold or fur-covered are not realistic options.
But if you need a perfect solution for your individual needs, ACE has the tools and expertise to make it happen.

Call our experts
+1 800-521-3220 or go to www.acecontrols.com

HB-12 to HB-70

Linear motion control

Adjustable

Compression and extension force 4 lbs to 11,240 lbs

Stroke 0.98 in to 31.50 in

High quality and long service life: The hydraulic dampers of the product family HB can also be used as single or double acting brake. Its coated body and piston rods with wear-resistant surface treatment are features of high quality and long service life.

The maintenance free, ready-to-install and closed systems provide a constant feed rate and are adjustable. The control segment on the piston makes adjustment at the end position child's play. Thanks to a broad selection of end fittings the assembly is easy to mount, so that the damper can be universally deployed for damping swinging masses, such as in power or free conveyors.

On automotive, automation and machine building, medical technology or the electronics and furniture industry, these machine elements are found in a number of different areas.

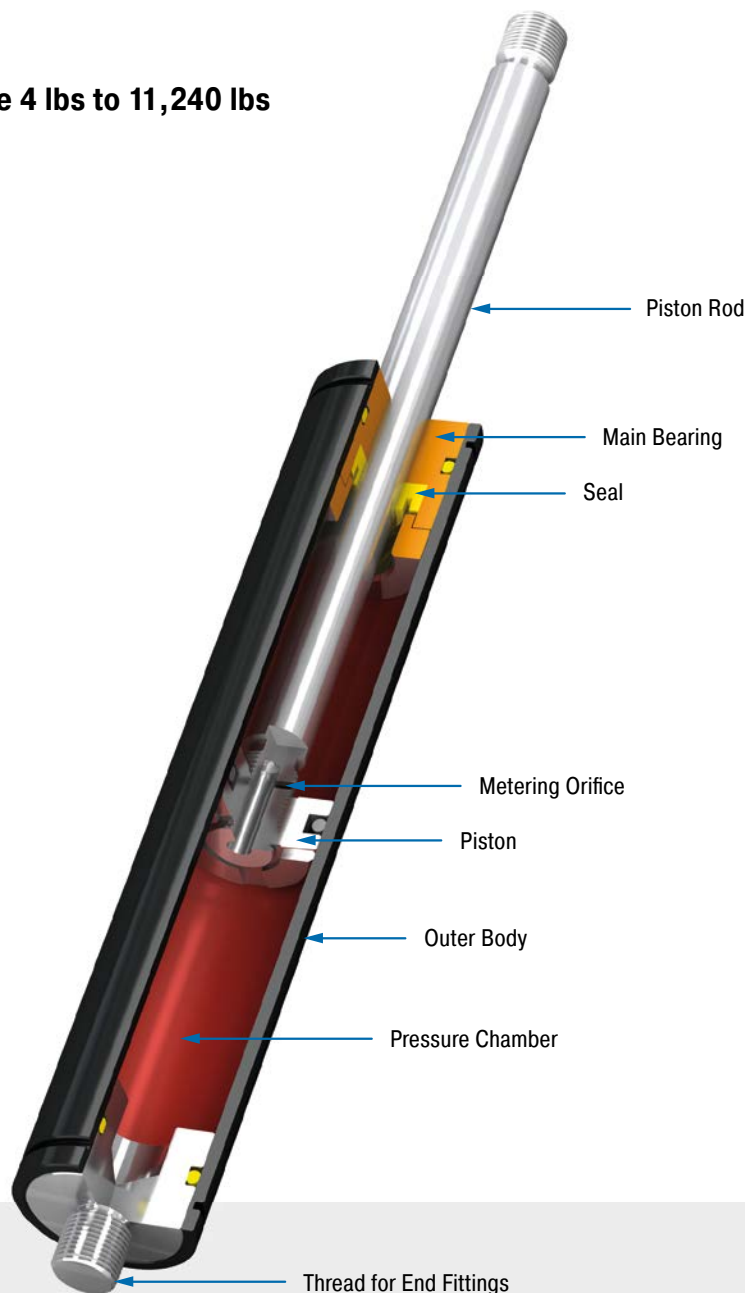

Technical Data

Compression and extension force: 4 lbs to 11,240 lbs

Outer body diameter: Ø 0.47 in to Ø 2.76 in

Piston rod diameter: Ø 0.16 in to Ø 1.18 in

Lifetime: Approx. 250,000 cycles

Free travel: Construction of the damper results in a free travel of approx. 20 % of stroke.

Separator piston: Available as a special option without free travel achieved by separator piston and nitrogen accumulator.

Operating temperature range: -4 °F to 176 °F

Adjustment: Achieved by turning the piston rod in its fully extended or fully compressed position.

Positive stop: External positive stops 0.04 in to 0.24 in before the end of stroke provided by the customer.

Damping medium: Hydraulic oil

Material: Outer body: Coated steel; Piston rod: Steel or stainless steel with wear-resistant coating; End fittings: Zinc plated steel

Mounting: In any position

Application field: Conveyor systems, Transport systems, Furniture industry, Locking systems, Sports equipment

Note: Increased break-away force if unit has not moved for some time.

End fittings: They are interchangeable and if necessary must be positively secured by the customer to prevent unscrewing.

On request: Special oils and other special options. Alternative accessories available on request.

Adjustable, Compression and extension force 4 lbs to 40 lbs

End Fitting

Standard Dimensions

End Fitting

A3.5

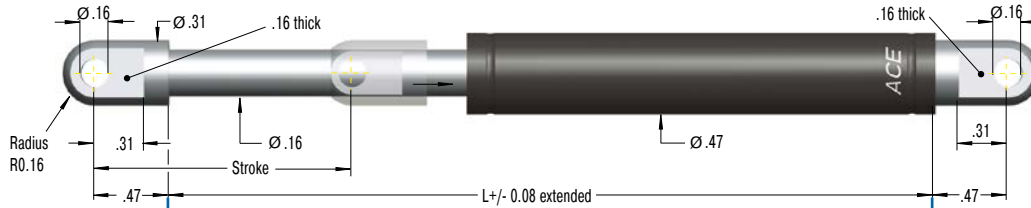

Eye A3.5
max. force 83 lbs

B3.5

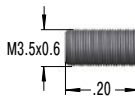

Performance and Dimensions

TYPES	Stroke inch	L extended inch	¹ Compression force max. lbs
HB-12-10	0.39	2.17	40.47
HB-12-20	0.79	2.95	40.47
HB-12-30	1.18	3.74	40.47
HB-12-40	1.57	4.53	40.47
HB-12-50	1.97	5.31	40.47
HB-12-60	2.36	6.10	40.47
HB-12-70	2.76	6.89	40.47
HB-12-80	3.15	7.68	33.72

¹ Max. extension force for all stroke lengths 40 lbs.

Stud Thread B3.5

C3.5

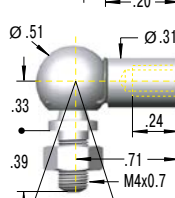

Angle Ball Joint C3.5
max. force 83 lbs

D3.5

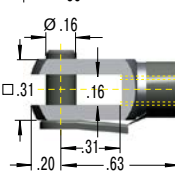

Clevis Fork D3.5
max. force 83 lbs

E3.5

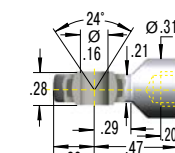

Swivel Eye E3.5
max. force 83 lbs

G3.5

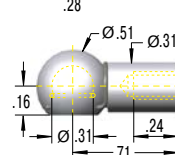

Ball Socket G3.5
max. force 83 lbs

Ordering Example

HB-12-30-AC-M

Type (Hydraulic Damper) _____
 Body 0.47" (12 mm) _____
 Stroke 1.18" (30 mm) _____
 Piston Rod End Fitting A3.5 _____
 Body End Fitting C3.5 _____
 Damping Direction (M = out stroke only) _____

Model Type Prefix

- P: Damping in both directions
- N: Damping on in stroke only
- M: Damping on out stroke only
- X: Special model suffix

Mounting accessories see from page 212.

Rod Shroud W3.5-12

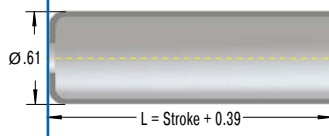

Technical Data

Compression and extension force: 4 lbs to 40 lbs

Free travel: Construction of the damper results in a free travel of approx. 21 % of stroke.

Separator piston: Available as a special option without free travel achieved by separator piston and nitrogen accumulator.

Operating temperature range: -4 °F to 176 °F

Adjustment: Achieved by turning the piston rod in its fully extended or fully compressed position.

Clockwise rotation = increase of the damping

Anti-clockwise rotation = decrease of the damping

Damping force adjustable before installation. Adjustment can add a max. of 0.24 in to the L dimension.

Positive stop: External positive stops 0.04" to 0.06" before the end of stroke provided by the customer.

Material: Outer body: Coated steel; Piston rod: Stainless steel (1.4301/1.4305, AISI 304/303); End fittings: Zinc plated steel

Mounting: In any position

Note: Increased break-away force if unit has not moved for some time.

End fittings: They are interchangeable and if necessary must be positively secured by the customer to prevent unscrewing.

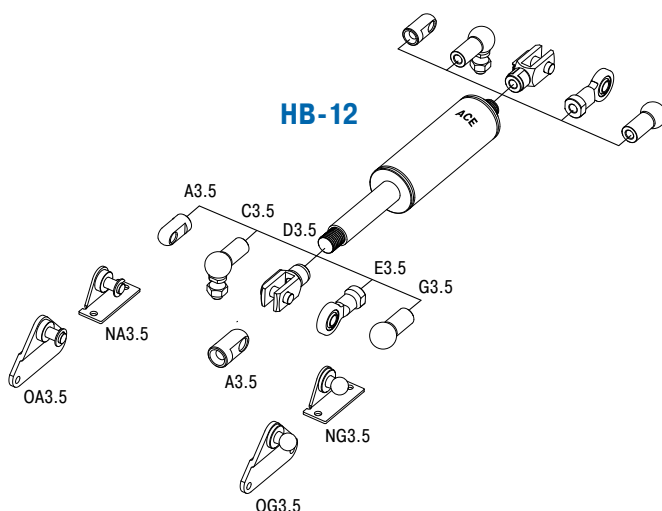

Adjustable, Compression and extension force 4 lbs to 180 lbs

End Fitting

Standard Dimensions

End Fitting

Performance and Dimensions

TYPES	Stroke inch	L extended inch	¹ Compression force max. lbs
HB-15-25	0.98	3.54	179.85
HB-15-50	1.97	5.51	179.85
HB-15-75	2.95	7.48	179.85
HB-15-100	3.94	9.5	78.68
HB-15-150	5.91	13.39	67.44

¹ Max. extension force for all stroke lengths 180 lbs.

Ordering Example

HB-15-150-AA-P

Type (Hydraulic Damper) _____
 Body 0.59" (15 mm) _____
 Stroke 5.91" (150 mm) _____
 Piston Rod End Fitting A5 _____
 Body End Fitting A5 _____
 Damping Direction (P = in both directions) _____

Model Type Prefix

P: Damping in both directions
 N: Damping on in stroke only
 M: Damping on out stroke only
 X: Special model suffix

Mounting accessories see from page 212.

Technical Data

Compression and extension force: 4 lbs to 180 lbs

Free travel: Construction of the damper results in a free travel of approx. 20 % of stroke.

Separator piston: Available as a special option without free travel achieved by separator piston and nitrogen accumulator.

Operating temperature range: -4 °F to 176 °F

Adjustment: Achieved by turning the piston rod in its fully extended or fully compressed position.

Clockwise rotation = increase of the damping

Anti-clockwise rotation = decrease of the damping

Damping force adjustable before installation. Adjustment can add a max. of 0.24 in to the L dimension.

Positive stop: External positive stops 0.04" to 0.06" before the end of stroke provided by the customer.

Material: Outer body: Black anodized aluminium; Piston rod: Steel with wear-resistant coating; End fittings: Zinc plated steel

Mounting: In any position

Note: Increased break-away force if unit has not moved for some time.

End fittings: They are interchangeable and if necessary must be positively secured by the customer to prevent unscrewing.

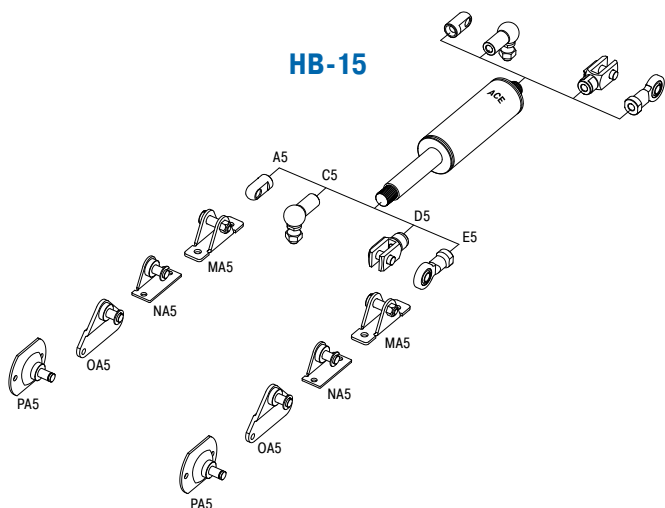

Adjustable, Compression and extension force 7 lbs to 405 lbs

End Fitting

Standard Dimensions

End Fitting

End Fitting A8
max. force 674 lbs

End Fitting Eye A8
max. force 674 lbs

End Fitting Stud Thread B8

End Fitting Angle Ball Joint C8
max. force 270 lbs
Also available with UNF thread 5/16-18. Order G5/16.

End Fitting Clevis Fork D8
max. force 674 lbs

End Fitting Swivel Eye E8
max. force 674 lbs

Performance and Dimensions

TYPES	Stroke inch	L extended inch	¹ Compression force max. lbs
HB-22-50	1.97	5.90	404.66
HB-22-100	3.94	9.84	404.66
HB-22-150	5.91	13.78	404.66
HB-22-200	7.87	17.72	224.81
HB-22-250	9.84	21.65	224.81
HB-22-300	11.81	25.58	179.85
HB-22-350	13.78	29.52	134.89
HB-22-400	15.75	33.46	89.92

¹ Max. extension force for all stroke lengths 405 lbs.

Ordering Example

HB-22-150-AA-P

Type (Hydraulic Damper) _____
 Body 0.87" (22 mm) _____
 Stroke 5.90" (150 mm) _____
 Piston Rod End Fitting A8 _____
 Body End Fitting A8 _____
 Damping Direction (P = in both directions) _____

Model Type Prefix

P: Damping in both directions
 N: Damping on in stroke only
 M: Damping on out stroke only
 X: Special model suffix

Mounting accessories see from page 212.

Technical Data

Compression and extension force: 7 lbs to 405 lbs

Free travel: Construction of the damper results in a free travel of approx. 20 % of stroke.

Separator piston: Available as a special option without free travel achieved by separator piston and nitrogen accumulator.

Operating temperature range: -4 °F to 176 °F

Adjustment: Achieved by turning the piston rod in its fully extended or fully compressed position.

Clockwise rotation = increase of the damping

Anti-clockwise rotation = decrease of the damping

Damping force adjustable before installation. Adjustment can add a max. of 0.24 in to the L dimension.

Positive stop: External positive stops 0.04" to 0.06" before the end of stroke provided by the customer.

Material: Outer body: Black anodized aluminium; Piston rod: Steel with wear-resistant coating; End fittings: Zinc plated steel

Mounting: In any position

Note: Increased break-away force if unit has not moved for some time.

End fittings: They are interchangeable and if necessary must be positively secured by the customer to prevent unscrewing.

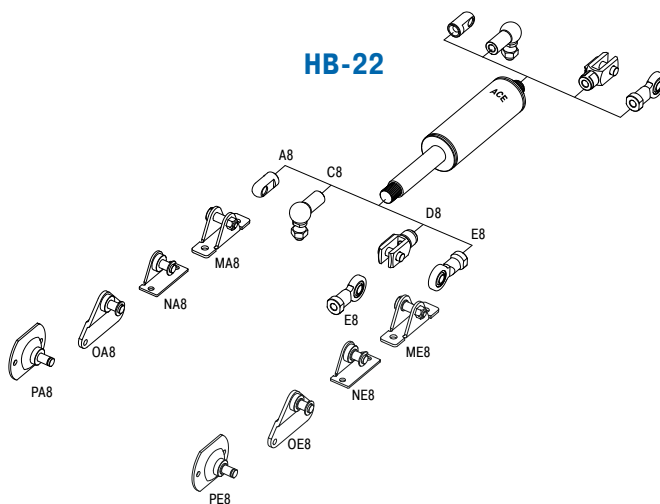

Adjustable, Compression and extension force 7 lbs to 674 lbs

End Fitting

Standard Dimensions

End Fitting

Performance and Dimensions

TYPES	Stroke inch	L extended inch	¹ Compression force max. lbs
HB-28-50	1.97	6.30	674.43
HB-28-100	3.94	10.24	674.43
HB-28-150	5.91	14.17	674.43
HB-28-200	7.87	18.11	674.43
HB-28-250	9.84	22.05	674.43
HB-28-300	11.81	25.98	562.03
HB-28-350	13.78	29.92	449.62
HB-28-400	15.75	33.86	337.22
HB-28-500	19.69	41.73	224.81

¹ Max. extension force for all stroke lengths 674 lbs.

Ordering Example

HB-28-150-AA-P

Type (Hydraulic Damper) _____
 Body 1.10" (28 mm) _____
 Stroke 5.91" (150 mm) _____
 Piston Rod End Fitting A8 _____
 Body End Fitting A8 _____
 Damping Direction (P = in both directions) _____

Model Type Prefix

P: Damping in both directions
 N: Damping on in stroke only
 M: Damping on out stroke only
 X: Special model suffix

Mounting accessories see from page 212.

End Fitting Options:
 Eye A8 max. force 674 lbs
 Stud Thread B8
 Angle Ball Joint C8 max. force 270 lbs
 Also available with UNF thread 5/16-18. Order G5/16.
 Clevis Fork D8 max. force 674 lbs
 Swivel Eye E8 max. force 674 lbs

Technical Data

Compression and extension force: 7 lbs to 674 lbs

Free travel: Construction of the damper results in a free travel of approx. 20 % of stroke.

Separator piston: Available as a special option without free travel achieved by separator piston and nitrogen accumulator.

Operating temperature range: -4 °F to 176 °F

Adjustment: Achieved by turning the piston rod in its fully extended or fully compressed position.

Clockwise rotation = increase of the damping

Anti-clockwise rotation = decrease of the damping

Damping force adjustable before installation. Adjustment can add a max. of 0.24 in to the L dimension.

Positive stop: External positive stops 0.04" to 0.06" before the end of stroke provided by the customer.

Material: Outer body: Black anodized aluminium; Piston rod: Steel with wear-resistant coating; End fittings: Zinc plated steel

Mounting: In any position

Note: Increased break-away force if unit has not moved for some time.

End fittings: They are interchangeable and if necessary must be positively secured by the customer to prevent unscrewing.

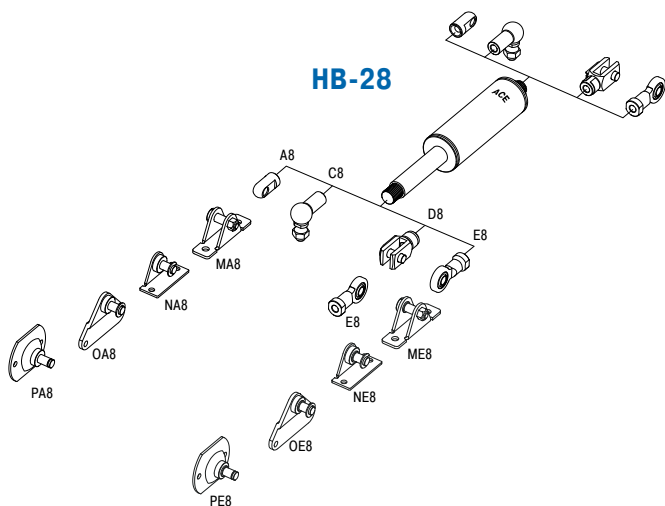

Adjustable, Compression and extension force 7 lbs to 2,248 lbs

End Fitting

Standard Dimensions

End Fitting

End Fitting A14
max. force 2,248 lbs

Eye A14
max. force 2,248 lbs

Stud Thread B14

Angle Ball Joint C14
max. force 719 lbs

Clevis Fork D14
max. force 2,248 lbs

Swivel Eye E14
max. force 2,248 lbs

Performance and Dimensions

TYPES	Stroke inch	L extended inch	¹ Compression force max. lbs
HB-40-100	3.94	10.83	2,248.10
HB-40-150	5.91	14.76	2,248.10
HB-40-200	7.87	18.70	2,248.00
HB-40-300	11.81	26.57	2,248.00
HB-40-400	15.75	34.45	1,798.48
HB-40-500	19.69	42.32	1,348.86
HB-40-600	23.62	50.20	899.24
HB-40-700	27.56	58.07	674.43
HB-40-800	31.50	65.94	674.43

¹ Max. extension force for all stroke lengths 2,248 lbs.

Ordering Example

HB-40-300-AA-P

Type (Hydraulic Damper) _____ ↑ ↑ ↑ ↑ ↑
 Body 1.57" (40 mm) _____ ↑ ↑ ↑ ↑ ↑
 Stroke 11.81" (300 mm) _____ ↑ ↑ ↑ ↑ ↑
 Piston Rod End Fitting A14 _____ ↑ ↑ ↑ ↑ ↑
 Body End Fitting A14 _____ ↑ ↑ ↑ ↑ ↑
 Damping Direction (P = in both directions) _____ ↑ ↑ ↑ ↑ ↑

Model Type Prefix

P: Damping in both directions
 N: Damping on in stroke only
 M: Damping on out stroke only
 X: Special model suffix

Mounting accessories see from page 212.

Technical Data

- Compression and extension force:** 7 lbs to 2,248 lbs
- Free travel:** Construction of the damper results in a free travel of approx. 20 % of stroke.
- Separator piston:** Available as a special option without free travel achieved by separator piston and nitrogen accumulator.
- Operating temperature range:** -4 °F to 176 °F
- Adjustment:** Achieved by turning the piston rod in its fully extended or fully compressed position.
 Clockwise rotation = increase of the damping
 Anti-clockwise rotation = decrease of the damping
 Damping force adjustable before installation. Adjustment can add a max. of 0.24 in to the L dimension.
- Positive stop:** External positive stops 0.04" to 0.06" before the end of stroke provided by the customer.
- Material:** Outer body: Black anodized aluminium; Piston rod: Steel with wear-resistant coating; End fittings: Zinc plated steel
- Mounting:** In any position
- Note:** Increased break-away force if unit has not moved for some time.
- End fittings:** They are interchangeable and if necessary must be positively secured by the customer to prevent unscrewing.

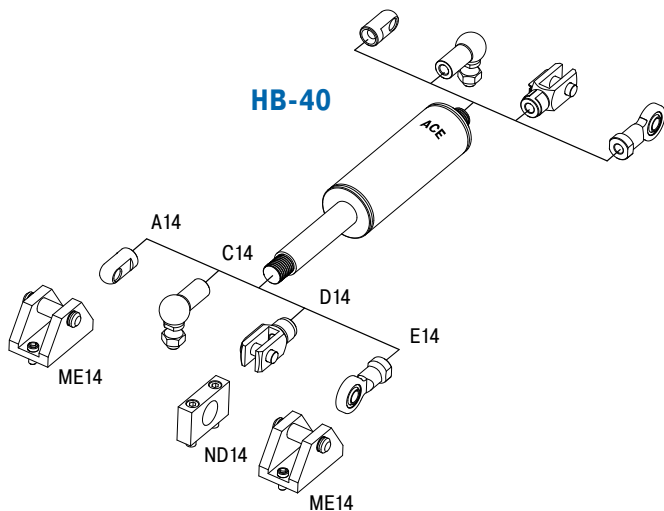

Issue 04.2018 – Specifications subject to change

Adjustable, Compression and extension force 450 lbs to 11,241 lbs

End Fitting

Standard Dimensions

End Fitting

B24 Stud Thread **B24**

D24 Clevis Fork **D24**
max. force 11,240 lbs

E24 Swivel Eye **E24**
max. force 11,240 lbs

Performance and Dimensions

TYPES	Stroke inch	L extended inch	¹ Compression force max. lbs
HB-70-100	4.37	13.03	11,240
HB-70-200	8.31	20.91	11,240
HB-70-300	12.24	28.78	11,240
HB-70-400	16.18	36.65	6,812
HB-70-500	20.12	44.53	4,856
HB-70-600	24.06	52.40	3,642
HB-70-700	27.99	60.28	2,833
HB-70-800	31.93	68.15	2,271

¹ Max. extension force for all stroke lengths 11,241 lbs.

Ordering Example

HB-70-300-EE-N

Type (Hydraulic Damper) _____
 Body 2.76" (70 mm) _____
 Stroke 11.81" (300 mm) _____
 Piston Rod End Fitting E24 _____
 Body End Fitting E24 _____
 Damping Direction (N = in stroke only) _____

Model Type Prefix

P: Damping in both directions
 N: Damping on in stroke only
 M: Damping on out stroke only
 X: Special model suffix

Mounting accessories see from page 212.

Rod Shroud W24-70

Ø 3.15
 L = Stroke + 5.12

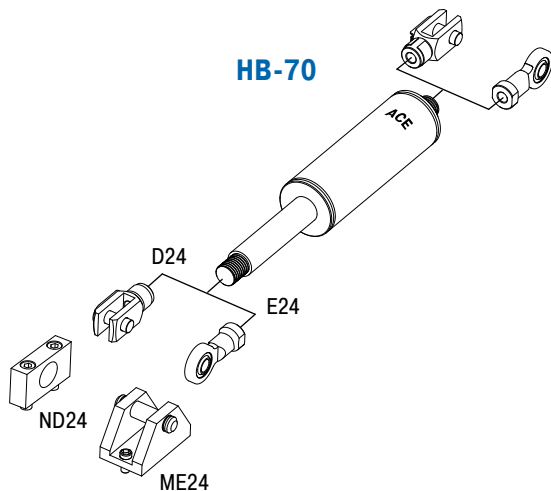

Technical Data

- Compression and extension force:** 450 lbs to 11,241 lbs
- Free travel:** Construction of the damper results in a free travel of approx. 20 % of stroke.
- Separator piston:** Available as a special option without free travel achieved by separator piston and nitrogen accumulator.
- Operating temperature range:** -4 °F to 176 °F
- Adjustment:** Achieved by turning the piston rod in its fully extended or fully compressed position.
- Positive stop:** External positive stops 0.20" to 0.24" before the end of stroke provided by the customer.
- Material:** Outer body: Coated steel; Piston rod: Hard chrome plated steel; End fittings: Zinc plated steel
- Mounting:** In any position
- Note:** Increased break-away force if unit has not moved for some time.
- End fittings:** They are interchangeable and if necessary must be positively secured by the customer to prevent unscrewing.

ACE Digital Tools



For more information
about the calculation
service see page 188!

Print catalog? Everyone can.

ACE offers more:

- ▶ Downloads: Product information in many languages
- ▶ PC calculation software & online calculation service
- ▶ Extensive CAD component libraries
- ▶ ACE-YouTube channel with video tips
- ▶ VibroChecker – free award-winning iPhone App

All available at www.acecontrols.com

Application Examples

DVC-32

Precise unreeling

Hydraulic dampers bring the sled movement of this textile machine to a gentle stop. At the turning point of 287 lbs reeling spools, a sled should move up and down smoothly without causing a collision at the end of stroke position. The solution was provided by the hydraulic damper DVC-32-100. A self-contained sealed unit, ready to install and maintenance-free these units are ideal for precise control of speeds in both directions of travel. The travel speed is maintained throughout the entire stroke and can be independently adjusted in each direction of travel. Thanks to their compact design and wide choice of mounting accessories, these dampers could be easily integrated into this machine.

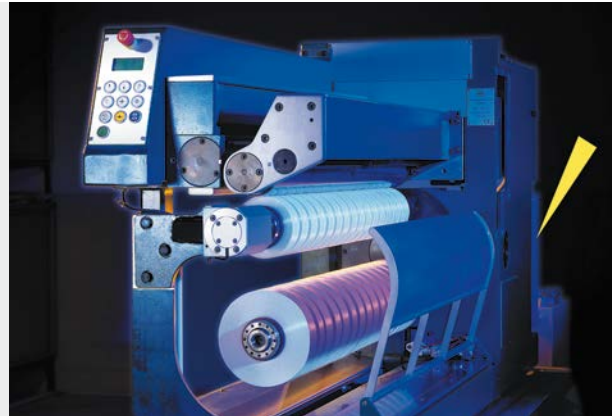
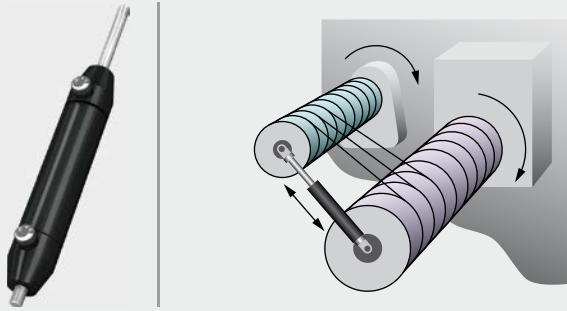

Textile machine unreels threads even better

HB-15

Operating speed of flaps top-regulated

In the past, operators of used-clothes containers could sustain injury because the flaps closed relatively quickly and uncontrollably. Various hydraulic dampers of the type HB-15, which are designed specifically for the type of container, regulate the synchronization of the flap in both directions and thereby serve to regulate the operating speed. To accommodate a range of requirements and to provide optimal protection against theft, different types with different strokes are mounted on flaps without damping, on large flaps with damping and on rotor flaps with damping.

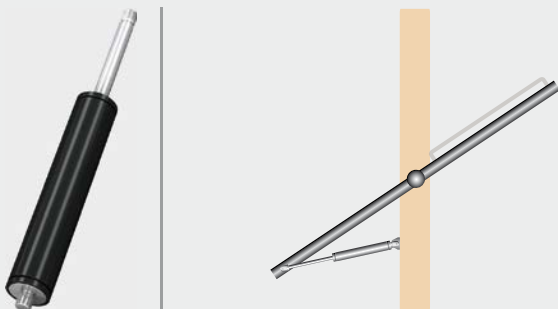

Hydraulic dampers prevent fingers becoming trapped in used-clothes containers as they ensure more gentle opening and closing movements
MCB Milieu & Techniek BV, 4704 SE Roosendaal, Netherlands

HB-40

Swinging movements cushioned by hydraulic dampers

Passengers always feel the swinging movement involved when cable cars arrive at the ski station. Maintenance-free hydraulic dampers type HB-40-300 cushion these movements perfectly. Designers of the cable cars, connected by means of an articulated joint via a four-point frame and connection guide to the suspension rod, profit from the ability of the adjustable dampers to absorb compressive forces of up to 2,248 lbs on either side.



Hydraulic dampers for added convenience when operating cable cars

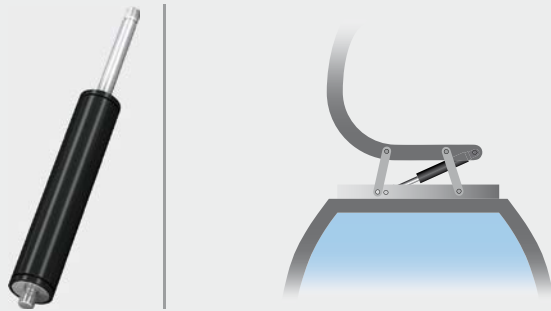

Mounting Accessories for steel gas springs and hydraulic dampers

By taking advantage of the very extensive range of ACE end fittings and mounting brackets you can easily and simply install our gas springs and hydraulic dampers. You profit from the variety of DIN standard end fittings such as swivel eyes, clevis forks, angle ball joints, inline ball joints, and included ball sockets.

ACE also offers eye fittings made of wear-resistant steel to meet the higher specification requirements found in industrial applications. With over 30 different types available these mounting accessories provide an extensive range of combinations for optimum installations.

With the ACE selection program you can choose not only your ACE gas springs but also the ideal end fittings and mounting brackets for your individual application example.

The complete range of accessories are also available as individual components.

**Infinite
Combinations!**

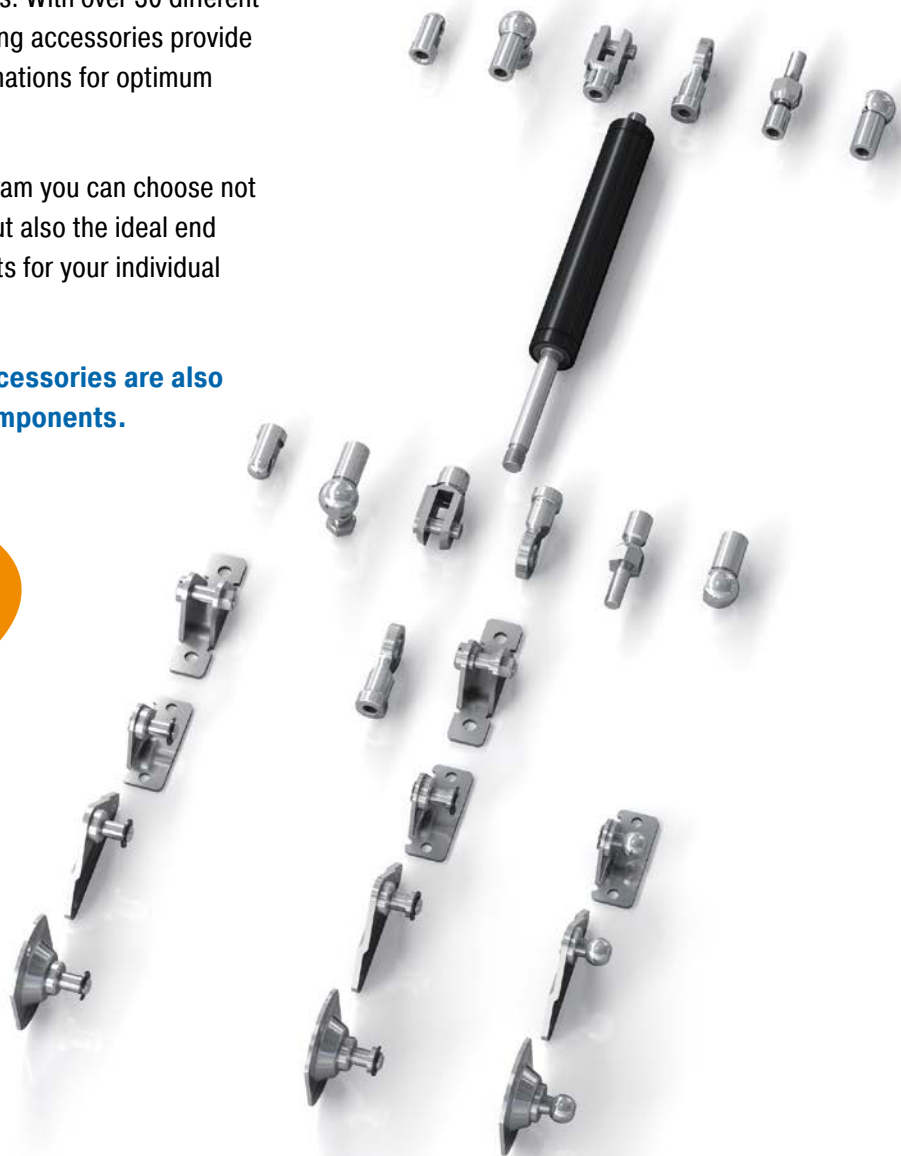

M3.5x0.6 (for GS-8, GS-10, GS-12, GZ-15, HB-12)

C3.5

Angle Ball Joint
DIN 71802

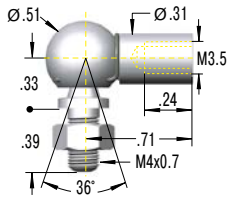

¹ max. force 83 lbs

E3.5

Swivel Eye
DIN 648

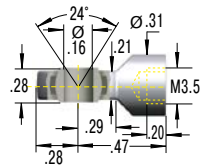

¹ max. force 83 lbs

A3.5

Eye

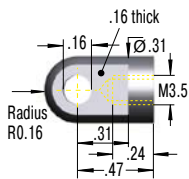

¹ max. force 83 lbs

NA3.5

Angle Bracket

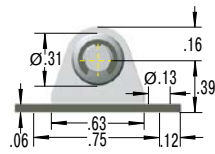

¹ max. force 40 lbs

OA3.5

Side Bracket

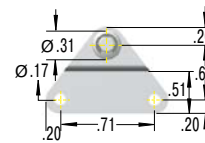
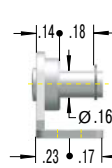

¹ max. force 40 lbs

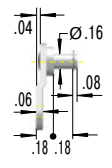

D3.5

Clevis Fork
DIN 71752

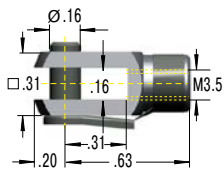

¹ max. force 83 lbs

A3.5

Eye

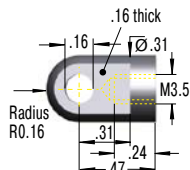

¹ max. force 83 lbs

G3.5

Ball Socket
DIN 71805

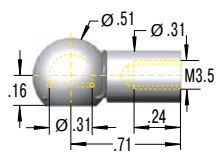

¹ max. force 83 lbs

NG3.5

Angle Bracket

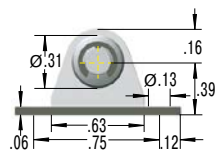

¹ max. force 40 lbs

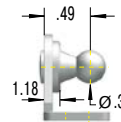

OG3.5

Side Bracket

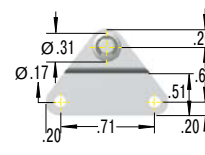

¹ max. force 40 lbs

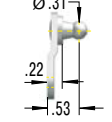

¹ Attention! Max. static load in Newtons. Beware force increase during compression (progression) and observe max. force limit.

M5x0.8 (for GS-15, HBD-15, HB-15)

C5
Angle Ball Joint
DIN 71802

¹ max. force 112 lbs

D5
Clevis Fork
DIN 71752

¹ max. force 180 lbs

F5
Inline Ball Joint

¹ max. force 112 lbs
Attention! Must only be used with compression loads.

A5
Eye

¹ max. force 180 lbs

MA5
Bearing Shoe

¹ max. force 112 lbs

NA5
Angle Bracket

¹ max. force 90 lbs



E5
Swivel Eye
DIN 648

¹ max. force 180 lbs

GSB-01
Side Bracket

¹ max. force 112 lbs

PA5
Round Bracket

¹ max. force 112 lbs

G5
Ball Socket
DIN 71805

¹ max. force 112 lbs

NG5
Angle Bracket

¹ max. force 90 lbs

GSB-02
Side Bracket

¹ max. force 112 lbs



PG5
Round Bracket

¹ max. force 112 lbs

¹ Attention! Max. static load in Newtons. Beware force increase during compression (progression) and observe max. force limit.

M8x1.25

(for GS-19, GS-22, GZ-19, HBD-22, HBD-28, HB-22, HB-28, DVC-32)

C8

Angle Ball Joint
DIN 71802

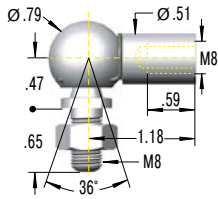

¹ max. force 270 lbs
Also available with UNF thread 5/16-18.
Order G5/16.

F8

Inline Ball Joint

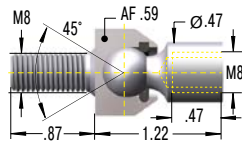

¹ max. force 270 lbs
Attention! Must only be used
with compression loads.

A8

Eye

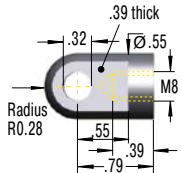

¹ max. force 674 lbs

MA8

Bearing Shoe

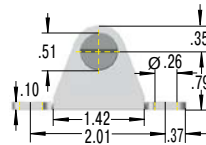

¹ max. force 405 lbs

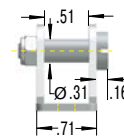

NA8

Angle Bracket

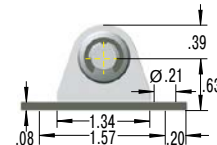

¹ max. force 225 lbs

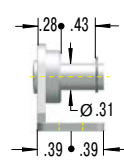

OA8

Side Bracket

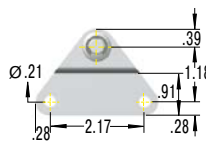

¹ max. force 270 lbs

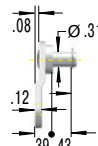

PA8

Round Bracket

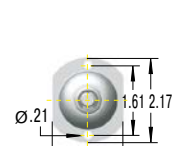

¹ max. force 270 lbs

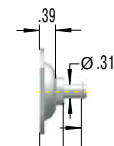

D8

Clevis Fork
DIN 71752

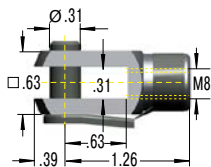

¹ max. force 674 lbs



E8

Swivel Eye
DIN 648

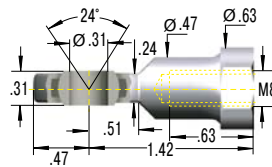

¹ max. force 674 lbs

¹ Attention! Max. static load in Newtons. Beware force increase during compression (progression) and observe max. force limit.

M8x1.25 (for GS-19, GS-22, GZ-19, HBD-22, HBD-28, HB-22, HB-28, DVC-32)

E8
Swivel Eye
DIN 648

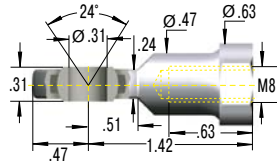

¹ max. force 674 lbs



ME8
Bearing Shoe

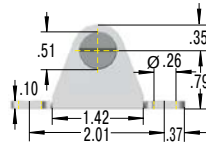

¹ max. force 405 lbs

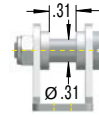

NE8
Angle Bracket

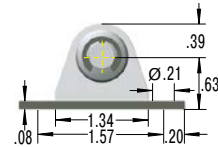

¹ max. force 225 lbs

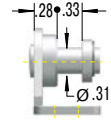

OE8
Side Bracket

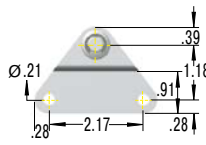

¹ max. force 270 lbs

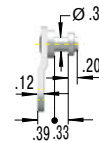

PE8
Round Bracket

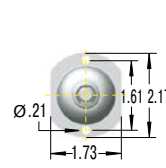

¹ max. force 270 lbs

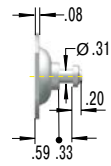

G8
Ball Socket
DIN 71805

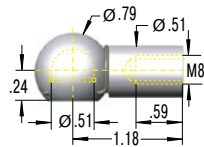

¹ max. force 270 lbs



NG8
Angle Bracket

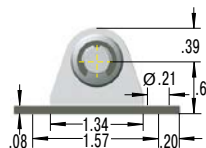

¹ max. force 225 lbs

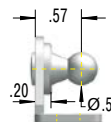

OG8
Side Bracket

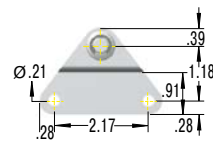

¹ max. force 270 lbs

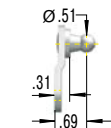

PG8
Round Bracket

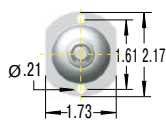

¹ max. force 270 lbs

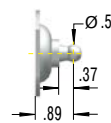

¹ Attention! Max. static load in Newtons. Beware force increase during compression (progression) and observe max. force limit.

M10x1.5 (for GS-28, GZ-28, HBD-50)

C10
Angle Ball Joint
DIN 71802

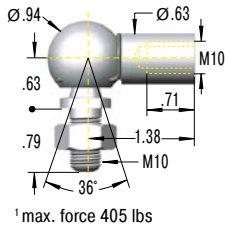

¹ max. force 405 lbs

F10
Inline Ball Joint

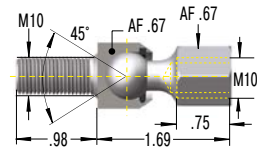

¹ max. force 405 lbs
Attention! Must only be used with compression loads.

A10
Eye

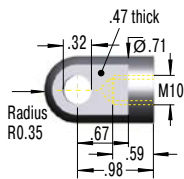

¹ max. force 2,248 lbs

MA10
Bearing Shoe

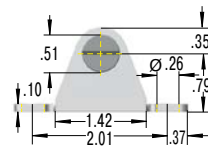

¹ max. force 405 lbs

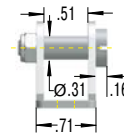

D10
Clevis Fork
DIN 71752

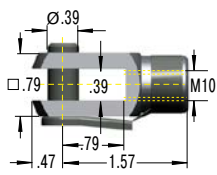

¹ max. force 2,248 lbs

E10
Swivel Eye
DIN 648

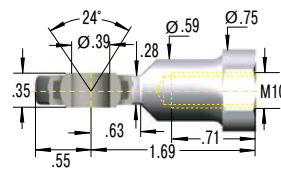

¹ max. force 2,248 lbs



E10
Swivel Eye
DIN 648

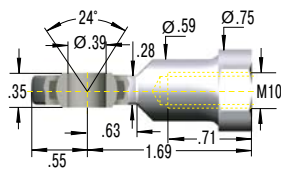

¹ max. force 2,248 lbs

ME10
Bearing Shoe

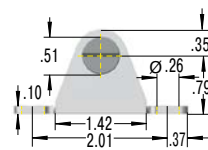

¹ max. force 405 lbs

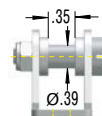

OE10
Side Bracket

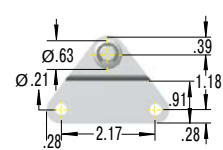

¹ max. force 270 lbs

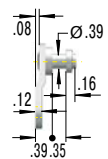

PE10
Round Bracket

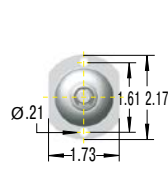

¹ max. force 270 lbs

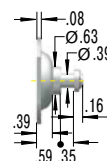

M24x2 (for GS-70, HB-70)

D24
Clevis Fork
DIN 71752

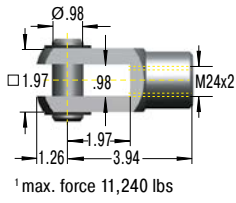

ND24
Mounting Flange

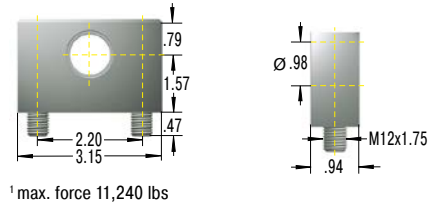

E24
Swivel Eye
DIN 648

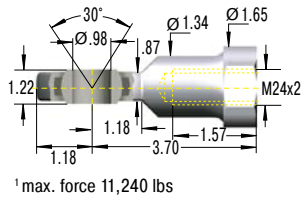

ME24
Bearing Shoe

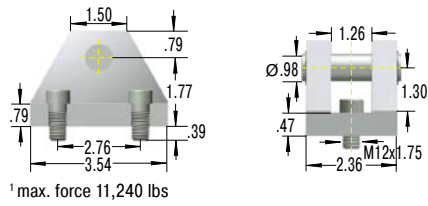

¹Attention! Max. static load in Newtons. Beware force increase during compression (progression) and observe max. force limit.

Mounting Accessories for stainless steel gas springs and hydraulic dampers

For our gas springs and hydraulic dampers made of stainless steel we also offer a flexible product range of DIN standardized end fittings and mounting brackets. These eyes, swivel eyes, clevis forks, angle ball joints, ball sockets, inline ball joints and mounting brackets are also made of sturdy stainless steel and can be easily combined.

The high-quality stainless steel accessories are rustproof and weakly magnetic. Just as with the corresponding stainless steel gas springs and hydraulic dampers, they are preferred in the food, electronics and ship building industries along with medical and cleanroom technology.

All ACE stainless steel gas springs and the appropriate mounting accessories are individually designed for each application with the ACE calculation program.

The entire range of stainless steel accessories is also available separately.

**Infinite
Combinations!**

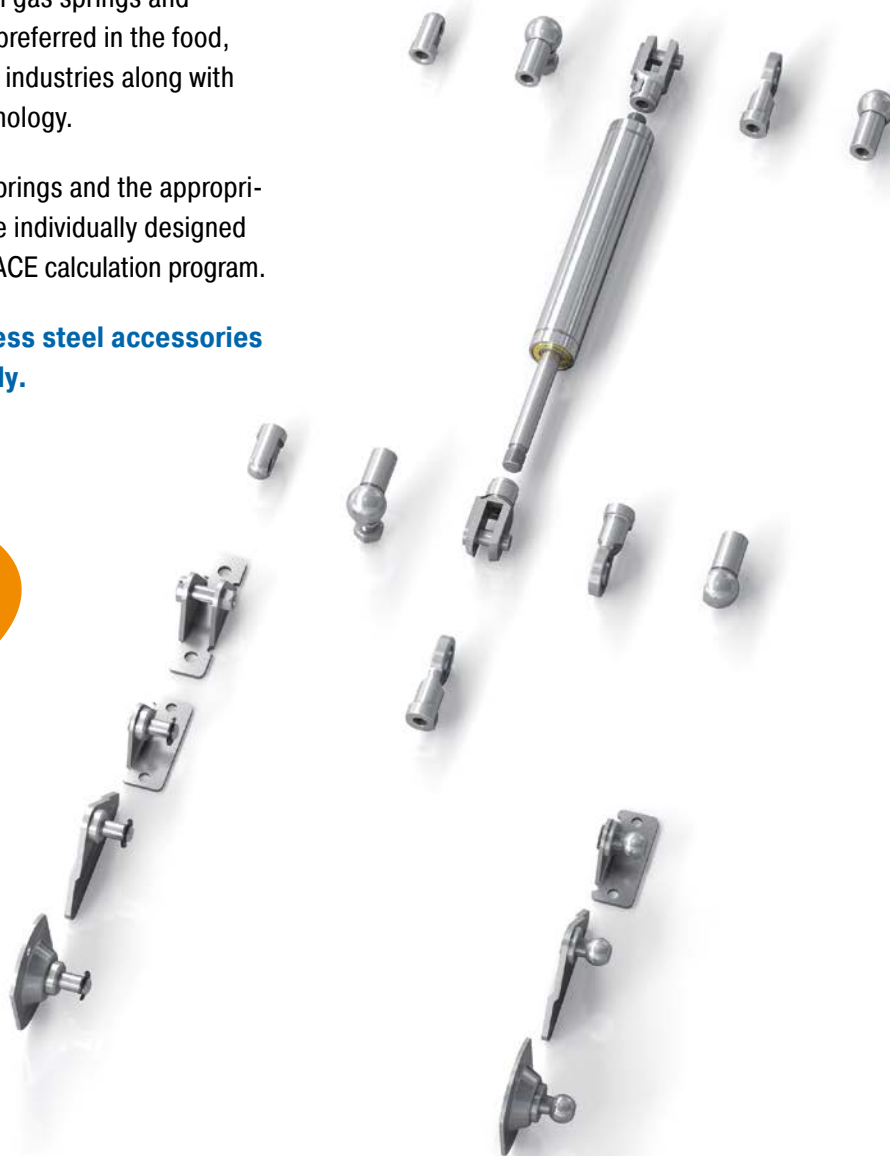

M3.5x0.6

(for GS-8-V4A, GS-10-V4A, GS-12-V4A, GZ-15-V4A)

C3.5-V4A Angle Ball Joint

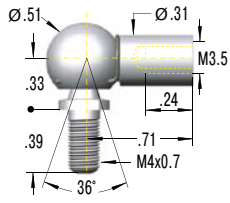

¹ max. force 83 lbs

A3.5-V4A Eye

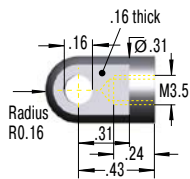

¹ max. force 83 lbs



NA3.5-V4A Angle Bracket

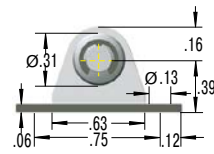

¹ max. force 40 lbs

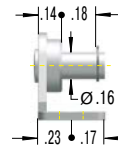

OA3.5-V4A Side Bracket

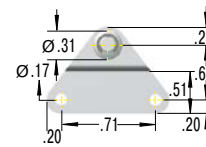

¹ max. force 40 lbs

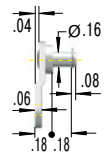

D3.5-V4A Clevis Fork

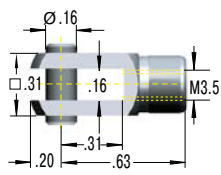

¹ max. force 83 lbs



A3.5-V4A Eye

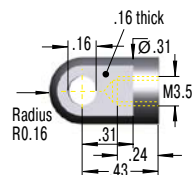

¹ max. force 83 lbs

G3.5-V4A Ball Socket

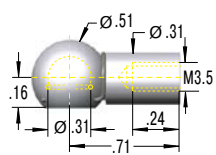

¹ max. force 83 lbs



NG3.5-V4A Angle Bracket

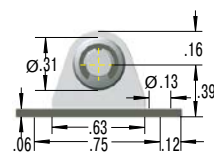

¹ max. force 40 lbs

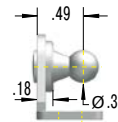

OG3.5-V4A Side Bracket

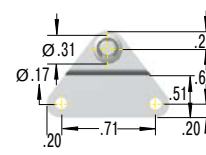

¹ max. force 40 lbs

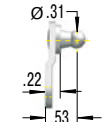

¹ Attention! Max. static load in Newtons. Beware force increase during compression (progression) and observe max. force limit.

M5x0.8 (for GS-15-VA)

C5-VA
Angle Ball Joint

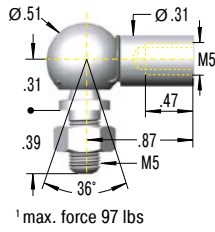

D5-VA
Clevis Fork

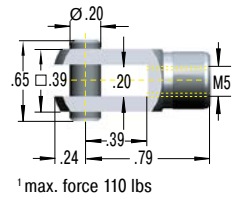

E5-VA
Swivel Eye

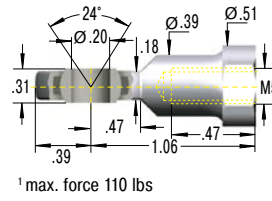

A5-VA
Eye

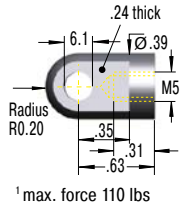

MA5-V4A
Bearing Shoe

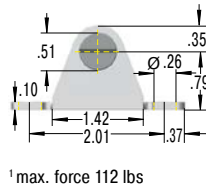

NA5-V4A
Angle Bracket

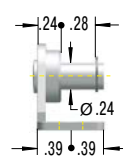
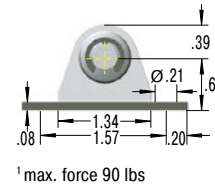

OA5-V4A
Side Bracket

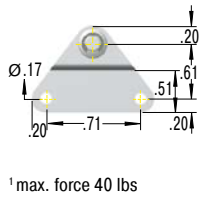

PA5-V4A
Round Bracket

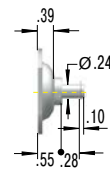
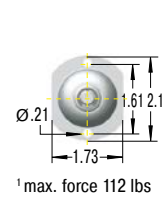

G5-VA
Ball Socket

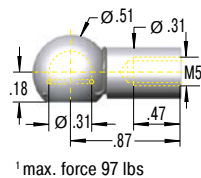

NG5-V4A
Angle Bracket

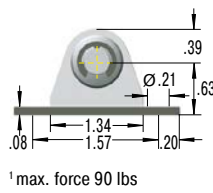

OG5-V4A
Side Bracket

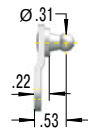
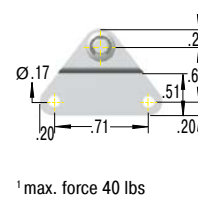

PG5-V4A
Round Bracket

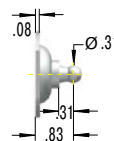
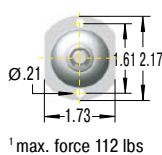

¹ Attention! Max. static load in Newtons. Beware force increase during compression (progression) and observe max. force limit.

M8x1.25 (for GS-19-VA, GS-22-VA, GZ-19-VA)

C8-VA
Angle Ball Joint

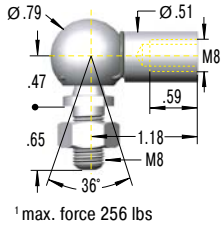

D8-VA
Clevis Fork

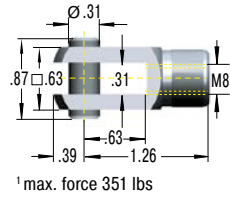

A8-VA
Eye

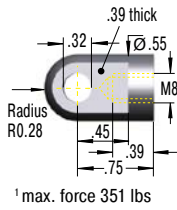

MA8-V4A
Bearing Shoe

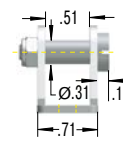
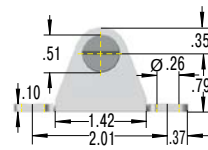

NA8-V4A
Angle Bracket

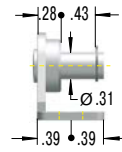
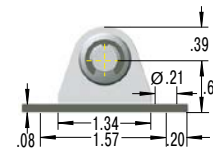

OA8-V4A
Side Bracket

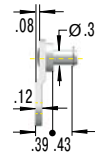
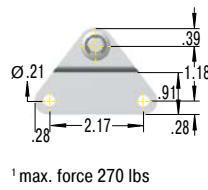

PA8-V4A
Round Bracket

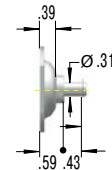
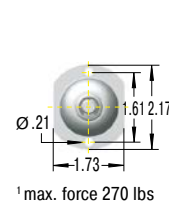

E8-VA
Swivel Eye

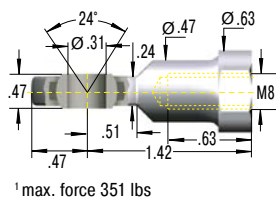

MA8-V4A
Bearing Shoe

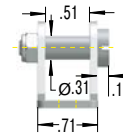
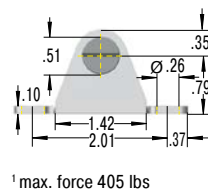

¹Attention! Max. static load in Newtons. Beware force increase during compression (progression) and observe max. force limit.

M8x1.25 (for GS-19-VA, GS-22-VA, GZ-19-VA)

G8-VA
Ball Socket

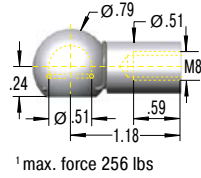

NG8-V4A
Angle Bracket

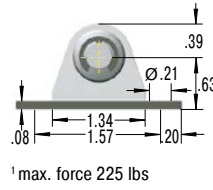

OG8-V4A
Side Bracket

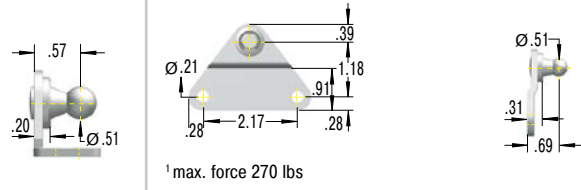

PG8-V4A
Round Bracket

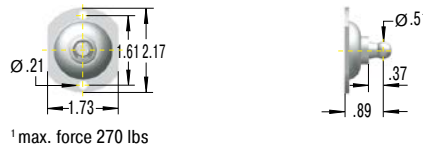

M10x1.5 (for GS-28-VA, GZ-28-VA)

C10-VA
Angle Ball Joint

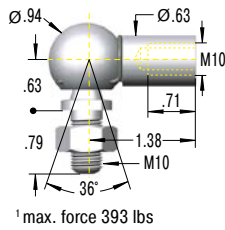

D10-VA
Clevis Fork

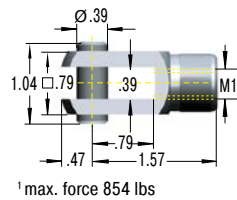

E10-VA
Swivel Eye

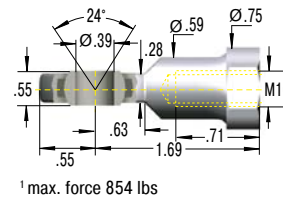

A10-VA
Eye

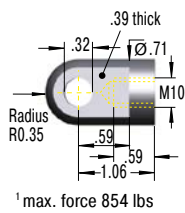

MA10-V4A
Bearing Shoe

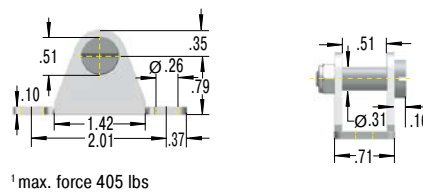

1 Attention! Max. static load in Newtons. Beware force increase during compression (progression) and observe max. force limit.

M14x1.5 (for GS-40-VA, GZ-40-VA)

C14-VA Angle Ball Joint

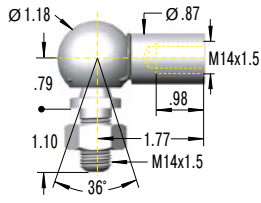

¹ max. force 719 lbs

A14-VA Eye

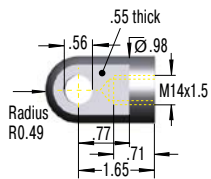

¹ max. force 1,574 lbs



ME14-VA Bearing Shoe

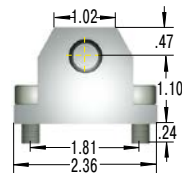

¹ max. force 2,248 lbs

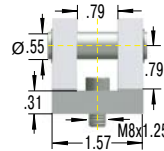

D14-VA Clevis Fork

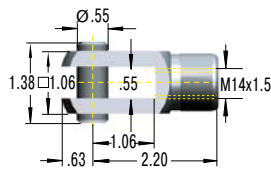

¹ max. force 1,574 lbs



ND14-VA Mounting Flange

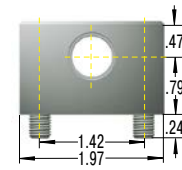

¹ max. force 2,248 lbs

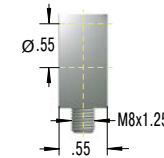

E14-VA Swivel Eye

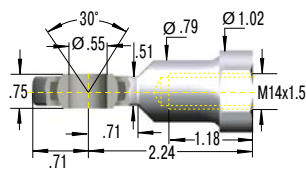

¹ max. force 1,574 lbs



ME14-VA Bearing Shoe

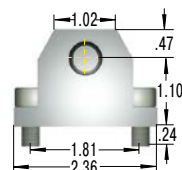

¹ max. force 2,248 lbs

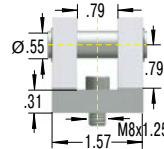

¹ Attention! Max. static load in Newtons. Beware force increase during compression (progression) and observe max. force limit.